

FRONT VIEW

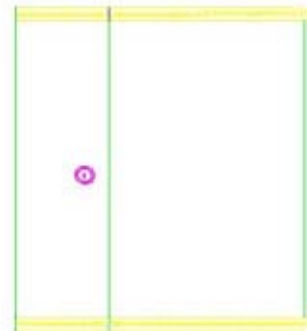

SIDE VIEW

1. Base Frame Assembly

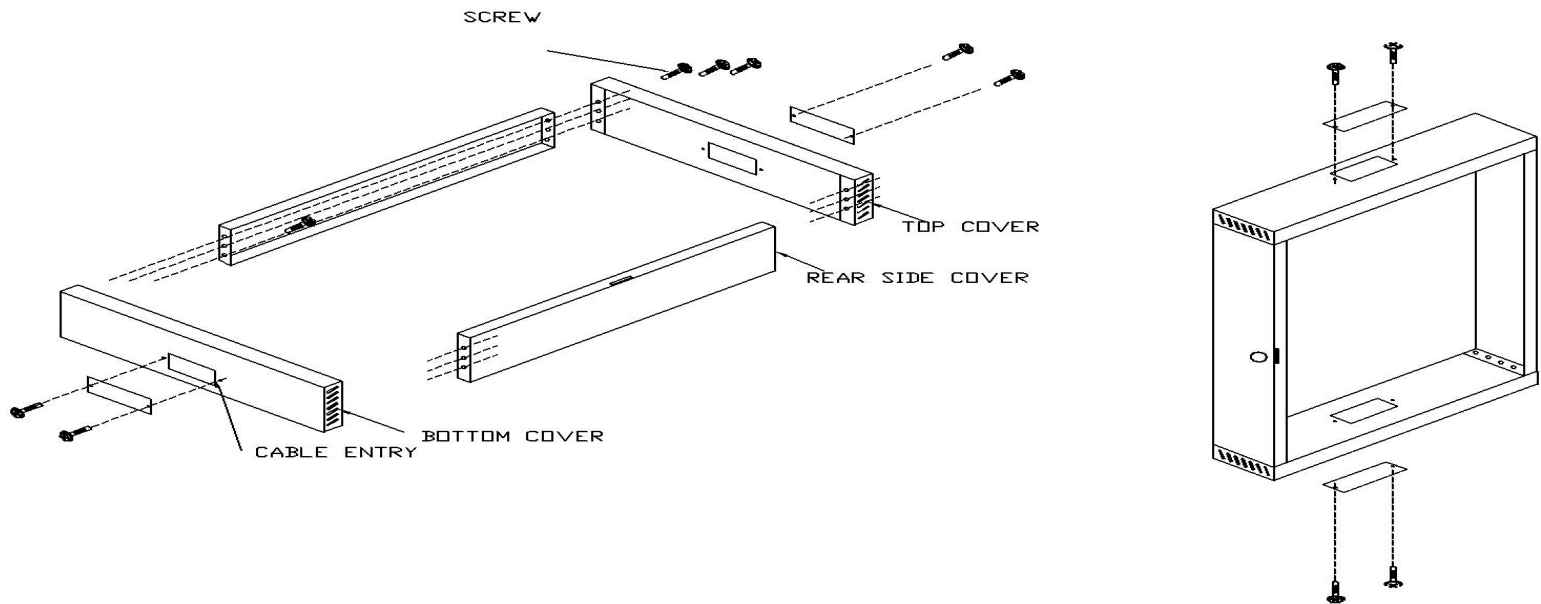

- Place Rear Side Cover on the Bottom Cover and tighten it with M6x10 screw
- Place Top Cover on top of both Rear Side Cover and use M6x10 screw & nut tighten it
- Base Frame is used to Mounted on the wall

2. Lock, Hinges and Power Distribution Assembly

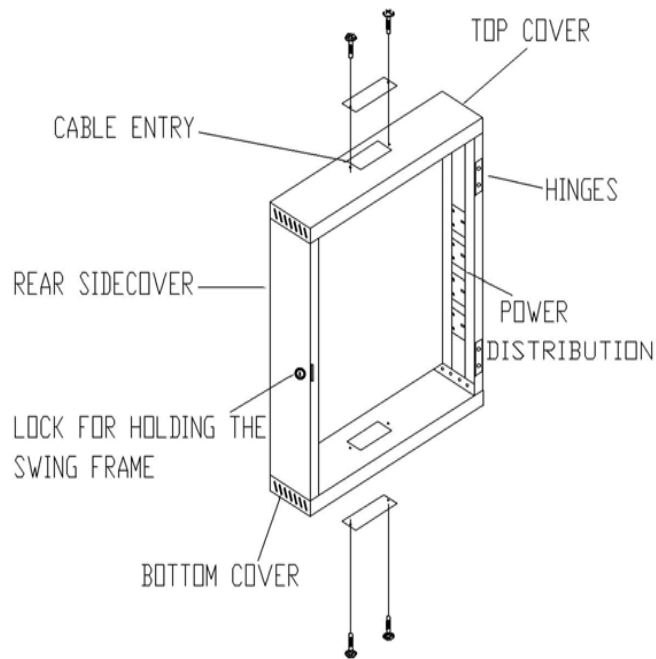

- Fix the lock and hinges as shown
- Power Distribution assembly will be done by supplier

3. Swing Frame Assembly

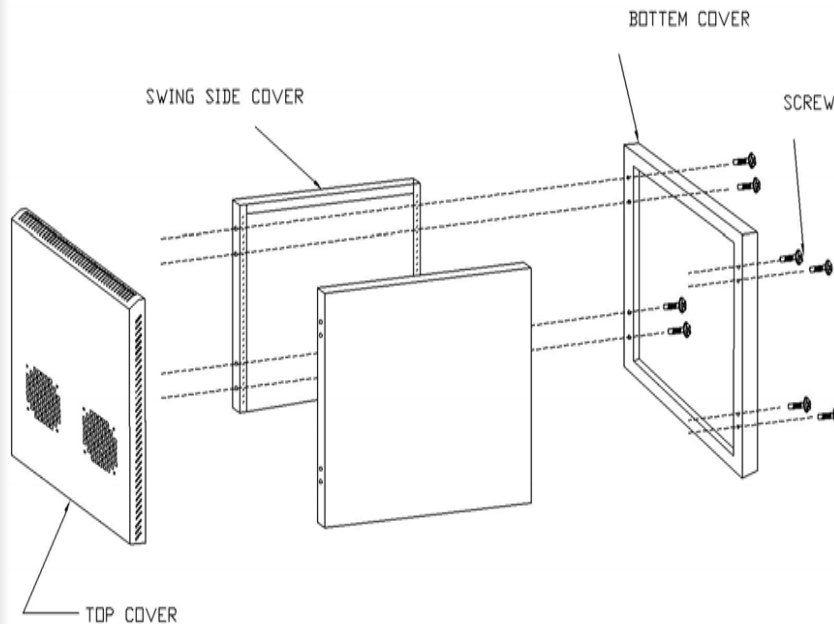

- Place Swing Side Cover on the Bottom Cover and tighten it with M6x10 screw
- Place Top Cover on top of the Swing Side Cover and use M6x10 Screw Nut to tighten it

4. Mounting Element Assembly

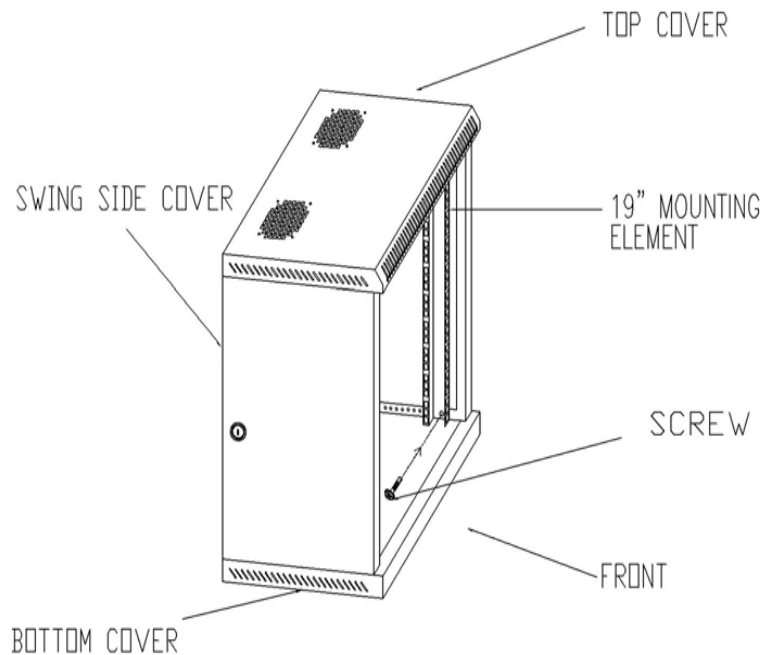

- The 19" Mounting Element is assembled to the Side Cover with M6x10 screw nut
- Repeat procedure above for assemble the rest Mounting Element
- Every Swing Frame has 4 numbers Mounting Element

5. Joining 2 Part Together

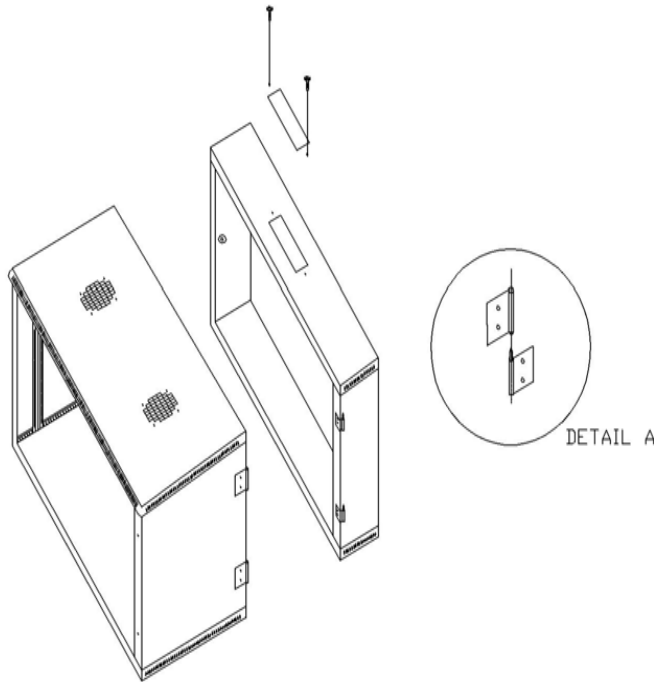

- One part of the hinge is assemble at the base frame, another part of the hinge will be screwed onto the Swing Frame using M4 CSK Screw
- Lift up the Swing Frame and insert into the hinge on the Base Frame

6. Front Glass Door Assembly

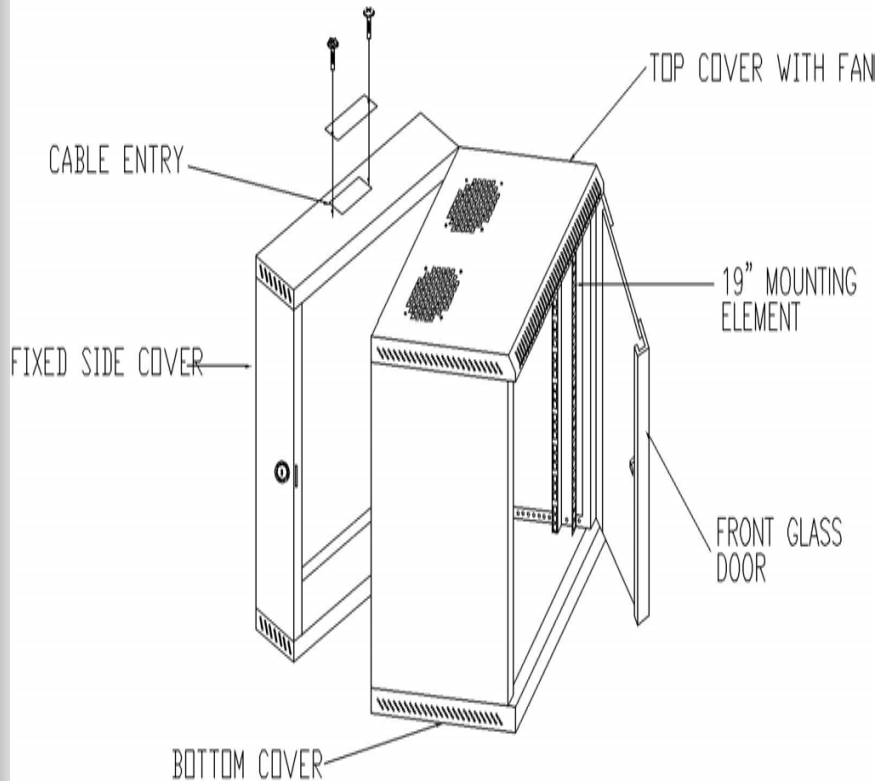

- Fix the Front Glass Door onto Swing Frame with using M6x10 screw

End Of Presentation

***Thank You for buying Closed-loop
Product***