



# Desktop Rack Assembly Procedure

**[Assembly Procedure]**

**[Roy Ho]**

**27/07/2004**

# 1. Side Cover Assembly

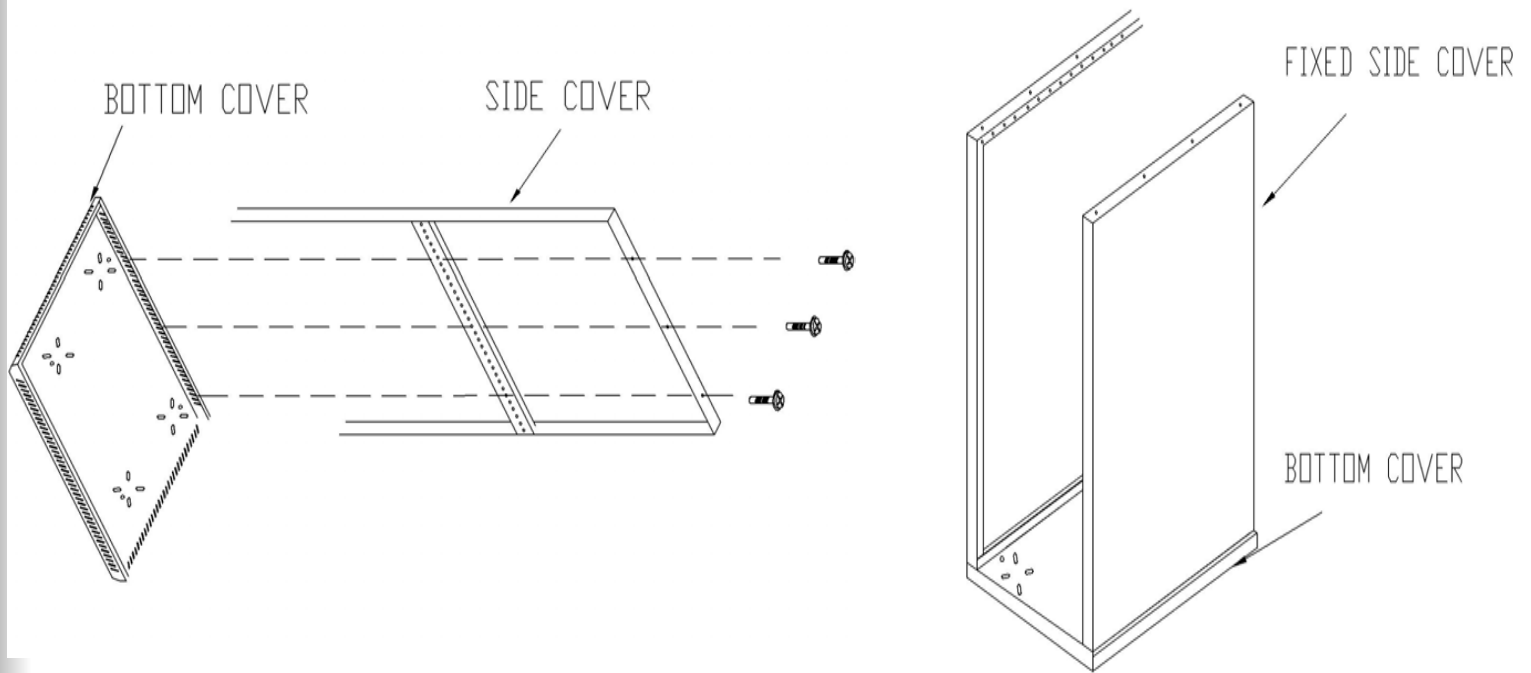

- Place Side Cover on top of the Bottom Cover
- Use M6x10 screw & nut to tighten it with the Bottom Cover
- Repeat procedure above for assemble next Side Cover

## 2. Roof Top & Castor Wheel Assembly

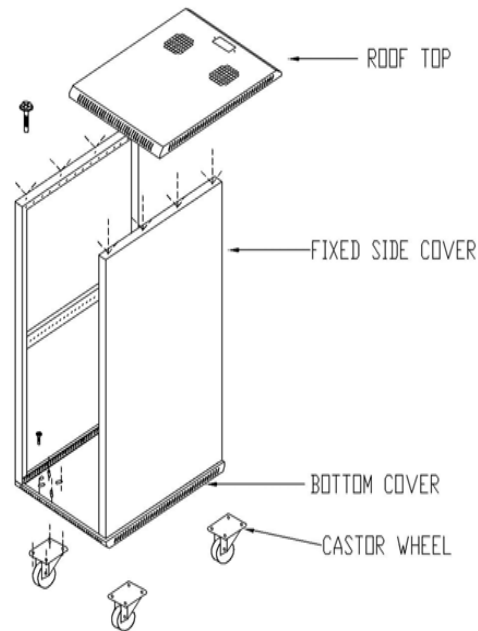

- Place Roof Top on top of the Side Cover
- Use M6x10 screw & nut to tighten it with Side Cover
- Castor Wheels are placed at Bottom Cover
- Tighten it with using M6x10 screw & nut

# 3. Mounting Element & Power Distribution Assembly

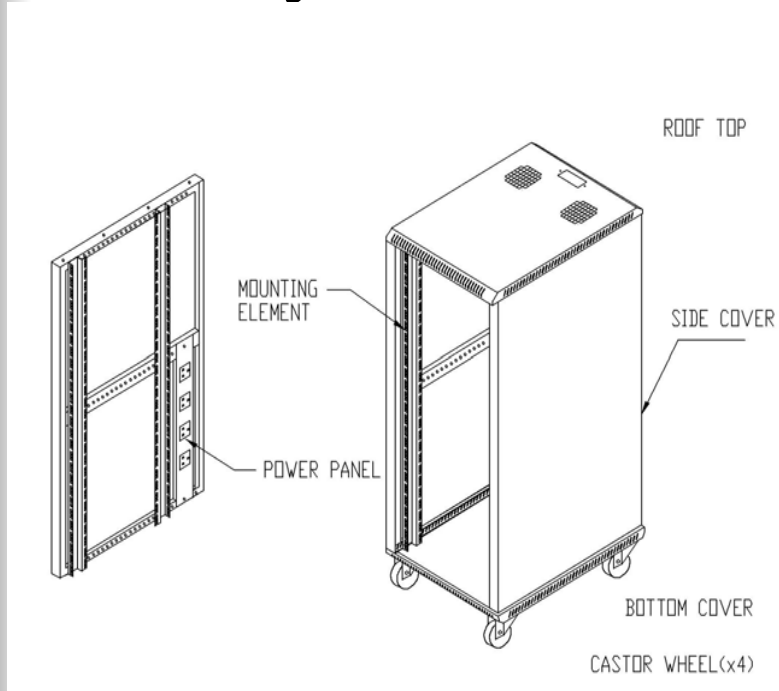

- Place Mounting Element on Side Cover and using M6x10 screw & nut to tighten it
- Repeat procedure above for assemble the rest of the Mounting Element
- Power Distribution Assembly will follow by Mounting Element Assembly.
- Place Power Distribution on Side Cover
- Use M6x10 screw & nut to tighten it

# 4. Front & Rear Door Assembly

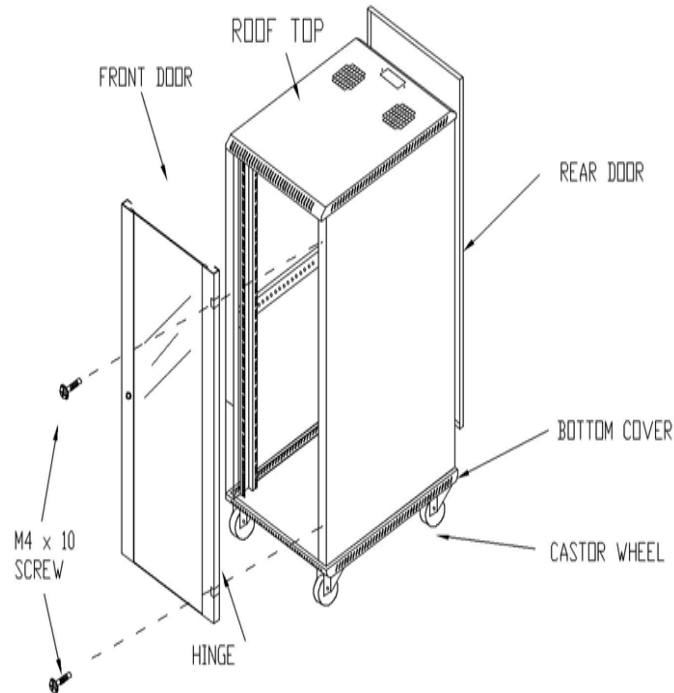

- **Fix one part of hinge onto Side Cover and another part of the hinge will be screwed onto Glass Door**
- **Ensure two hinges align and insert the pin**
- **Repeat procedure above for assembly the rear door**



*End Of Presentation*